

1200-5 SERIES FIVE ROLL FOR THIN WALL TUBES

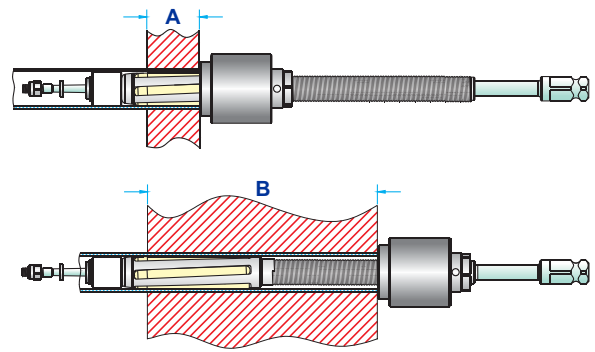
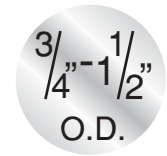

FOR TUBES INTERNAL DIAMETER
FROM (14.8 mm) .584" TO (36.3 mm) 1.43"

POWERMASTER INDUSTRIAL SUPPLIES LTD

Tel: (613) 764-0572 sales@tubetools.ca

TUBE EXPANDERS FITTED WITH ROLLER LENGTH	FOR TUBE SHEET ADJUSTABLE RANGE	
	MINIMUM A	MAXIMUM B
(38.1mm) 1.1/2"	STD. REACH	(38.1mm) 1.1/2" (152.4mm) 6"
	"A" REACH	(38.1mm) 1.1/2" (203.2mm) 8"
	"B" REACH	(38.1mm) 1.1/2" (253.8mm) 10"
	"C" REACH	(38.1mm) 1.1/2" (304.6mm) 12"
(57.1mm) 2.1/4"	STD. REACH	(57.1mm) 2.1/4" (171.4mm) 6.3/4"
	"A" REACH	(57.1mm) 2.1/4" (222.1mm) 8.3/4"
	"B" REACH	(57.1mm) 2.1/4" (272.8mm) 10.3/4"
	"C" REACH	(57.1mm) 2.1/4" (323.6mm) 12.3/4"

- Use : Highly recommended for use on thin walled tubes (19 thru 22 gage walls) of Stainless Steel, Titanium, Incoloy and other exotic materials in thick tube sheets.
- Advantages : Gives a more concentric and even expansion when expanding thin walled tubes vs. a conventional 3 roll expander and reduces tube spring back effect.
- Expanders for tube sizes not listed below are also available. Please enquire.

Tube O.D. (mm) inch	Tube Thickness			Tube I.D.		Minimum I.D. Tool Enters		Maximum Expansion of Tool		EXPANDER with (38.10 mm) 1.1/2" Long Rollers			EXPANDER with (57.15) 2.1/4" Long Rollers		
	bwg	mm	inch	mm	inch	mm	inch	mm	inch	Complete Tool No.	Mandrel No.	Rollers Set. No.	Complete Tool No.	Mandrel No.	Rollers Set. No.
(19.05) 3/4	14	2.10	.083	14.8	.584	14.5	.574	16.2	.639	1223-5	1224-5	R-6-5	1224-5	1224-5	R-6-A-5
	15	1.82	.072	15.3	.606	14.9	.590	16.7	.661	1225-5	1226-5	R-7-5	1226-5	1226-5	R-7-A-5
	16	1.65	.065	15.7	.620	15.3	.605	17.4	.685	1227-5	M-63	R-7-5	1228-5	M-63	R-7-A-5
	17	1.47	.058	16.1	.634	15.7	.619	17.8	.699	1229-5	1230-5	R-7-5	1230-5	1230-5	R-7-A-5
	18	1.24	.049	16.5	.652	15.7	.619	17.8	.699	1229-5	1230-5	R-7-5	1230-5	1230-5	R-7-A-5
	19	1.06	.042	16.9	.666	16.3	.642	18.5	.722	1231-5	M-63	R-9-5	1232-5	M-63	R-9-A-5
	20	0.88	.035	17.2	.680	16.3	.642	18.5	.722	1231-5	M-63	R-9-5	1232-5	M-63	R-9-A-5
	21	0.81	.032	17.4	.686	16.3	.642	18.5	.722	1231-5	M-63	R-9-5	1232-5	M-63	R-9-A-5
(25.40) 1	22	0.71	.028	17.6	.694	16.3	.642	18.5	.722	1231-5	M-63	R-9-5	1232-5	M-63	R-9-A-5
	14	2.10	.083	21.1	.834	20.5	.810	23.0	.909	1249-5	1250-5	R-12-5	1250-5	1250-5	R-12-A-5
	15	1.82	.072	21.7	.856	21.2	.837	23.7	.936	1251-5	1251-5	R-13-5	1252-5	1251-5	R-13-A-5
	16	1.65	.065	22.0	.870	21.2	.837	23.7	.936	1251-5	1251-5	R-13-5	1252-5	1251-5	R-13-A-5
	17	1.47	.058	22.4	.884	21.9	.865	24.4	.964	1255-5	1256-5	R-13-5	1256-5	1256-5	R-13-A-5
	18	1.24	.049	22.9	.902	21.9	.865	24.4	.964	1255-5	1256-5	R-13-5	1256-5	1256-5	R-13-A-5
	19	1.06	.042	23.2	.916	21.9	.865	24.4	.964	1255-5	1256-5	R-13-5	1256-5	1256-5	R-13-A-5
	20	0.88	.035	23.6	.930	21.9	.865	24.4	.964	1255-5	1256-5	R-13-5	1256-5	1256-5	R-13-A-5
(28.58) 1.1/8	21	0.81	.032	23.8	.936	22.4	.883	24.9	.982	1257-5	M-71-3/8	R-15-5	1258-5	M-71-3/8	R-15-A-5
	22	0.71	.028	24.0	.944	22.4	.883	24.9	.982	1257-5	M-71-3/8	R-15-5	1258-5	M-71-3/8	R-15-A-5
(38.10) 1.1/2	12	2.76	.109	23.0	.907	22.4	.883	24.9	.982	1257-5	M-71-3/8	R-15-5	1258-5	M-71-3/8	R-15-A-5
	15	1.82	.072	24.9	.981	24.4	.962	27.2	1.071	1263-5	1263-5	R-18-5	-	-	-
(38.10) 1.1/2	16	1.65	.065	25.2	.995	24.4	.962	27.2	1.071	1263-5	1263-5	R-18-5	-	-	-
	17	1.47	.058	35.1	1.384	33.8	1.331	37.3	1.472	1299-5	1299-5	R-29-5	1300-5	1299-5	R-29-A-5
	18	1.24	.049	35.6	1.402	33.8	1.331	37.3	1.472	1299-5	1299-5	R-29-5	1300-5	1299-5	R-29-A-5
	19	1.06	.042	36.0	1.416	33.8	1.331	37.3	1.472	1299-5	1299-5	R-29-5	1300-5	1299-5	R-29-A-5
20	0.89	.035	36.3	1.430	33.8	1.331	37.3	1.472	1299-5	1299-5	R-29-5	1300-5	1299-5	R-29-A-5	

For best results a 'Thin Wall Thrust Collar' should be used when rolling 19 thru 22 gauge wall tubes. (See Pg. 5)

Model 1223-5 - 1258-5 expanders come with 3/8" square mandrel drives and Model 1263-5 - 1300-5 expanders come with 1/2" square mandrel drives.