

# 1200 SERIES LONG REACH

1/2" - 1 1/2"  
O.D.

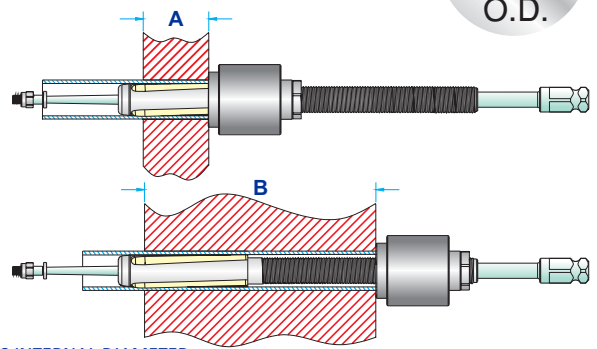

FOR TUBES INTERNAL DIAMETER  
FROM (8.4 mm) .334" TO (36.3 mm) 1.43"

- Use : Most popular tool worldwide for heat exchangers and condensers with tubes of 5/8"-1.1/2" O.D. and thick tube sheets.
- Longer reach expanders are available. Please let us know reach needed.

TUBE EXPANDERS FITTED WITH ROLLER LENGTH		FOR TUBE SHEET ADJUSTABLE RANGE	
		MINIMUM A	MAXIMUM B
(38.1mm) 1.1/2"	STD. REACH	(38.1mm) 1.1/2"	(152.4mm) 6"
	"A" REACH	(38.1mm) 1.1/2"	(203.2mm) 8"
	"B" REACH	(38.1mm) 1.1/2"	(253.8mm) 10"
	"C" REACH	(38.1mm) 1.1/2"	(304.6mm) 12"
(57.1mm) 2.1/4"	STD. REACH	(57.1mm) 2.1/4"	(171.4mm) 6.3/4"
	"A" REACH	(57.1mm) 2.1/4"	(222.1mm) 8.3/4"
	"B" REACH	(57.1mm) 2.1/4"	(272.8mm) 10.3/4"
	"C" REACH	(57.1mm) 2.1/4"	(323.6mm) 12.3/4"

Tube O.D. (mm) inch	Tube Thickness			Tube I.D.		Minimum I.D. Tool Enters		Maximum Expansion of Tool		EXPANDER with (38.10 mm) 1.1/2" Long Rollers			EXPANDER with (57.15 mm) 2.1/4" Long Rollers		
	bwg	mm	inch	mm	inch	mm	inch	mm	inch	Complete Tool No.	Mandrel No.	Rollers Set. No.	Complete Tool No.	Mandrel No.	Rollers Set. No.
(12.70)  1/2	14	2.10	.083	8.4	.334	8.2	.324	9.5	.374	1197	1197	797	-	-	-
	15	1.82	.072	9.0	.356	8.8	.348	10.1	.398	1199	1199	R-1	-	-	-
	16	1.65	.065	9.4	.370	9.1	.360	10.4	.410	1201	M-51	R-1	-	-	-
	17	1.47	.058	9.7	.384	9.5	.374	10.7	.424	1203	M-51	R-2	-	-	-
	18	1.24	.049	10.2	.402	9.9	.392	11.3	.447	1205	M-52	R-3	-	-	-
(15.88)  5/8	20	0.88	.035	10.9	.430	10.3	.406	11.7	.461	1205 S	M-53	R-3	-	-	-
	12	2.76	.109	10.3	.407	9.9	.392	11.3	.447	1205	M-52	R-3	-	-	-
	13	2.41	.095	11.0	.435	10.8	.425	12.1	.480	1207	M-53	R-4	-	-	-
	14	2.10	.083	11.6	.459	11.4	.449	12.9	.509	1209	M-54	R-4	1210	M-54	R-4-A
	15	1.82	.072	12.2	.481	11.9	.471	13.6	.536	1211	M-55	R-5	1212	M-55	R-5-A
	16	1.65	.065	12.5	.495	12.3	.485	13.9	.550	1213	M-55	R-6	1214	M-55	R-6-A
	17	1.47	.058	12.9	.509	12.6	.499	14.3	.564	1215	M-56	R-6	1216	M-56	R-6-A
	18	1.24	.049	13.3	.527	13.1	.517	14.5	.572	1217	M-57	R-7	1218	M-57	R-7-A
	19	1.06	.042	13.7	.541	13.2	.522	14.7	.582	1219	M-56	R-7	1220	M-56	R-7-A
	20	0.88	.035	14.1	.555	13.6	.536	15.1	.596	1219 S	M-58	R-7	1220 S	M-58	R-7-A
(19.05)  3/4	21	0.81	.032	14.2	.561	13.6	.536	15.1	.596	1219 S	M-58	R-7	1220 S	M-58	R-7-A
	22	0.71	.028	14.4	.569	13.6	.536	15.1	.596	1219 S	M-58	R-7	1220 S	M-58	R-7-A
	10	3.40	.134	12.2	.482	11.9	.471	13.6	.536	1211	M-55	R-5	1212	M-55	R-5-A
	11	3.04	.120	12.9	.510	12.6	.499	14.3	.564	1215	M-56	R-6	1216	M-56	R-6-A
	12	2.76	.109	13.5	.532	13.2	.522	14.7	.582	1219	M-56	R-7	1220	M-56	R-7-A
	13	2.41	.095	14.2	.560	13.9	.550	15.6	.615	1221	M-58	R-8	1222	M-58	R-8-A
	14	2.10	.083	14.8	.584	14.5	.574	16.2	.639	1223	M-58	R-9	1224	M-58	R-9-A
	15	1.82	.072	15.3	.606	15.1	.596	16.7	.661	1225	M-58	R-10	1226	M-58	R-10-A
	16	1.65	.065	15.7	.620	15.3	.605	17.4	.685	1227	M-59	R-10	1228	M-59	R-10-A
	17	1.47	.058	16.1	.634	15.7	.619	17.7	.699	1229	M-59	R-11	1230	M-59	R-11-A
(22.22)  7/8	18	1.24	.049	16.5	.652	15.7	.619	17.7	.699	1229	M-59	R-11	1230	M-59	R-11-A
	19	1.06	.042	16.9	.666	16.3	.642	18.3	.722	1231	M-59	R-12	1232	M-59	R-12-A
	20	0.88	.035	17.2	.680	16.3	.642	18.3	.722	1231	M-59	R-12	1232	M-59	R-12-A
	21	0.81	.032	17.4	.686	16.3	.642	18.3	.722	1231	M-59	R-12	1232	M-59	R-12-A
	22	0.71	.028	17.6	.694	16.3	.642	18.3	.722	1231	M-59	R-12	1232	M-59	R-12-A
	10	3.40	.134	15.4	.607	15.1	.596	16.7	.661	1225	M-58	R-10	1226	M-58	R-10-A
	11	3.04	.120	16.1	.635	15.7	.619	17.7	.699	1229	M-59	R-11	1230	M-59	R-11-A
	12	2.76	.109	16.6	.657	16.3	.642	18.3	.722	1231	M-59	R-12	1232	M-59	R-12-A
	13	2.41	.095	17.4	.685	17.0	.670	19.0	.750	1233	M-60	R-13	1234	M-60	R-13-A
	14	2.10	.083	18.0	.709	17.4	.685	19.6	.774	1235	M-61	R-14	1236	M-61	R-14-A
15	1.82	.072	18.5	.731	18.0	.712	20.3	.801	1237	M-61	R-15	1238	M-61	R-15-A	
16	1.65	.065	18.9	.745	18.4	.726	20.7	.815	1239	M-62	R-15	1240	M-62	R-15-A	
17	1.47	.058	19.2	.759	18.8	.740	21.0	.829	1243	M-62	R-16	1244	M-62	R-16-A	
18	1.24	.049	19.7	.777	18.8	.740	21.0	.829	1243	M-62	R-16	1244	M-62	R-16-A	

Model 1197-1256 expanders come with 3/8" square mandrel drives and Model 1257-1300 expanders come with 1/2" square mandrel drives.

Tel: (613) 764-0572 sales@tubetools.ca



# 1200 SERIES LONG REACH

**POWERMATER INDUSTRIAL SUPPLIES LTD**

**Tel: (613) 764-0572 sales@tubetools.ca**

Tube O.D. (mm) inch	Tube Thickness			Tube I.D.		Minimum I.D. Tool Enters		Maximum Expansion of Tool		EXPANDER with (38.10 mm) 1.1/2" Long Rollers			EXPANDER with (57.15 mm) 2.1/4" Long Rollers		
	bwg	mm	inch	mm	inch	mm	inch	mm	inch	Complete Tool No.	Mandrel No.	Rollers Set. No.	Complete Tool No.	Mandrel No.	Rollers Set. No.
1 (25.40)	8	4.19	.165	17.0	.670	16.6	.655	18.6	.735	1241	M-59	R-13	1242	M-59	R-13-A
	9	3.75	.148	17.8	.704	17.4	.685	19.6	.774	1235	M-61	R-14	1236	M-61	R-14-A
	10	3.40	.134	18.5	.732	18.0	.712	20.3	.801	1237	M-61	R-15	1238	M-61	R-15-A
	11	3.04	.120	19.3	.760	18.8	.740	21.0	.829	1243	M-62	R-16	1244	M-62	R-16-A
	12	2.76	.109	19.8	.782	19.3	.763	21.6	.852	1245	M-62	R-17	1246	M-62	R-17-A
	13	2.41	.095	20.5	.810	20.0	.791	22.3	.880	1247	M-62	R-18	1248	M-62	R-18-A
	14	2.10	.083	21.1	.834	20.5	.810	23.0	.909	1249	M-63	R-18	1250	M-63	R-18-A
	15	1.82	.072	21.7	.856	21.2	.837	23.7	.936	1251	M-63	R-19	1252	M-63	R-19-A
	16	1.65	.065	22.1	.870	21.2	.837	23.7	.936	1251	M-63	R-19	1252	M-63	R-19-A
	17	1.47	.058	22.4	.884	21.9	.865	24.4	.964	1255	M-63	R-21	1256	M-63	R-21-A
	18	1.24	.049	22.9	.902	21.9	.865	24.4	.964	1255	M-63	R-21	1256	M-63	R-21-A
19	1.06	.042	23.2	.916	21.9	.865	24.4	.964	1255	M-63	R-21	1256	M-63	R-21-A	
20	0.88	.035	23.6	.930	21.9	.865	24.4	.964	1255	M-63	R-21	1256	M-63	R-21-A	
1.1/8 (28.58)	8	4.19	.165	20.1	.795	19.7	.776	22.2	.875	1253	M-63	R-20	1254	M-63	R-20-A
	9	3.75	.148	21.0	.829	20.5	.810	23.0	.909	1249	M-63	R-18	1250	M-63	R-18-A
	10	3.40	.134	21.7	.857	21.2	.837	23.7	.936	1251	M-63	R-19	1252	M-63	R-19-A
	11	3.04	.120	22.4	.885	21.9	.865	24.4	.964	1255	M-63	R-21	1256	M-63	R-21-A
	12	2.76	.109	23.0	.907	22.4	.883	24.9	.982	1257	M-64	R-21	1258	M-64	R-21-A
	13	2.41	.095	23.7	.935	23.2	.916	25.7	1.015	1259	M-64	R-22	1260	M-64	R-22-A
	14	2.10	.083	24.3	.959	23.7	.935	26.5	1.044	1261	M-65	R-23	1262	M-65	R-23-A
	15	1.82	.072	24.9	.981	24.4	.962	27.2	1.071	1263	M-65	R-24	1264	M-65	R-24-A
	16	1.65	.065	25.2	.995	24.4	.962	27.2	1.071	1263	M-65	R-24	1264	M-65	R-24-A
17	1.47	.058	25.6	1.010	25.1	.990	27.9	1.099	1267	M-66	R-26	1268	M-66	R-26-A	
18	1.24	.049	26.0	1.027	25.1	.990	27.9	1.099	1267	M-66	R-26	1268	M-66	R-26-A	
1.1/4 (31.75)	8	4.19	.165	23.3	.920	22.8	.901	25.6	1.010	1265	M-65	R-25	1266	M-65	R-25-A
	9	3.75	.148	24.2	.954	23.7	.935	26.5	1.044	1261	M-65	R-23	1262	M-65	R-23-A
	10	3.40	.134	24.9	.982	24.4	.962	27.2	1.071	1263	M-65	R-24	1264	M-65	R-24-A
	11	3.04	.120	25.6	1.010	25.1	.990	27.9	1.099	1267	M-66	R-26	1268	M-66	R-26-A
	12	2.76	.109	26.2	1.032	25.7	1.013	28.5	1.122	1269	M-66	R-27	1270	M-66	R-27-A
	13	2.41	.095	26.9	1.060	26.4	1.039	29.2	1.150	1271	M-67	R-28	1272	M-67	R-28-A
	14	2.10	.083	27.5	1.084	26.9	1.060	29.6	1.169	1273	M-67	R-29	1274	M-67	R-29-A
	15	1.82	.072	28.0	1.106	27.6	1.087	30.3	1.196	1275	M-67	R-30	1276	M-67	R-30-A
	16	1.65	.065	28.4	1.120	27.6	1.087	30.3	1.196	1275	M-67	R-30	1276	M-67	R-30-A
	17	1.47	.058	28.8	1.134	28.3	1.115	31.0	1.224	1279	M-68	R-30	1280	M-68	R-30-A
18	1.24	.049	29.2	1.152	28.3	1.115	31.0	1.224	1279	M-68	R-30	1280	M-68	R-30-A	
1.3/8 (34.92)	8	4.19	.165	26.5	1.045	26.0	1.026	28.8	1.135	1277	M-67	R-31	1278	M-67	R-31-A
	9	3.75	.148	27.4	1.079	26.9	1.060	29.6	1.169	1273	M-67	R-29	1274	M-67	R-29-A
	10	3.40	.134	28.1	1.107	27.6	1.087	30.3	1.196	1275	M-67	R-30	1276	M-67	R-30-A
	11	3.04	.120	28.8	1.135	28.3	1.115	31.0	1.224	1279	M-68	R-30	1280	M-68	R-30-A
	12	2.76	.109	29.3	1.157	28.7	1.133	31.5	1.242	1281	M-68	R-32	1282	M-68	R-32-A
	13	2.41	.095	30.1	1.185	29.4	1.160	32.3	1.275	1283	M-69	R-33	1284	M-69	R-33-A
	14	2.10	.083	30.7	1.209	29.9	1.179	32.8	1.294	1285	M-70	R-34	1286	M-70	R-34-A
	15	1.82	.072	31.2	1.231	30.6	1.206	33.5	1.321	1287	M-70	R-35	1288	M-70	R-35-A
16	1.65	.065	31.6	1.245	30.6	1.206	33.5	1.321	1287	M-70	R-35	1288	M-70	R-35-A	
1.1/2 (38.10)	8	4.19	.165	29.7	1.170	29.0	1.145	32.0	1.260	1289	M-69	R-34	1290	M-69	R-34-A
	9	3.75	.148	30.5	1.204	29.9	1.177	32.8	1.294	1285	M-70	R-34	1286	M-70	R-34-A
	10	3.40	.134	31.2	1.232	30.6	1.206	33.5	1.321	1287	M-70	R-35	1288	M-70	R-35-A
	11	3.04	.120	32.0	1.260	31.3	1.235	34.2	1.350	1291	M-70	R-36	1292	M-70	R-36-A
	12	2.76	.109	32.5	1.282	31.9	1.257	34.8	1.372	1293	M-70	R-37	1294	M-70	R-37-A
	13	2.41	.095	33.2	1.310	32.6	1.285	35.5	1.400	1295	M-71	R-37	1296	M-71	R-37-A
	14	2.10	.083	33.8	1.334	32.6	1.285	35.5	1.400	1295	M-71	R-37	1296	M-71	R-37-A
	15	1.82	.072	34.4	1.356	33.8	1.331	36.7	1.446	1297	M-71	R-38	1298	M-71	R-38-A
	16	1.65	.065	34.8	1.370	33.8	1.331	36.7	1.446	1297	M-71	R-38	1298	M-71	R-38-A
	17	1.47	.058	35.1	1.384	33.8	1.331	37.3	1.472	1299	M-72	R-38	1300	M-72	R-38-A
	18	1.24	.049	35.6	1.402	33.8	1.331	37.3	1.472	1299	M-72	R-38	1300	M-72	R-38-A
	19	1.06	.042	35.9	1.416	33.8	1.331	37.3	1.472	1299	M-72	R-38	1300	M-72	R-38-A
20	0.88	.035	36.3	1.430	33.8	1.331	37.3	1.472	1299	M-72	R-38	1300	M-72	R-38-A	

Model 1197-1256 expanders come with 3/8" square mandrel drives and Model 1257-1300 expanders come with 1/2" square mandrel drives.